

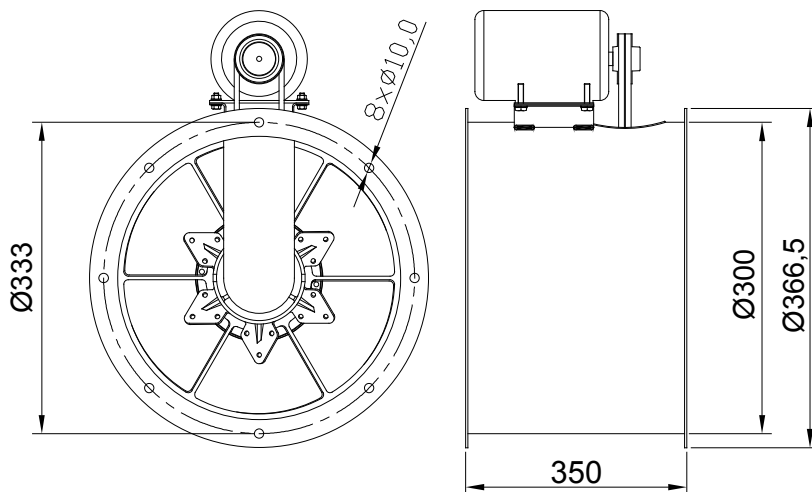

Exaustor EQ300TRT4

OBS. FOTO E DESENHOS ILUSTRATIVOS



ESQUEMA DE LIGAÇÃO
VIDE PLAQUETA DO MOTOR

CURVA CARACTERÍSTICA
(20°C/760 mm Hg)

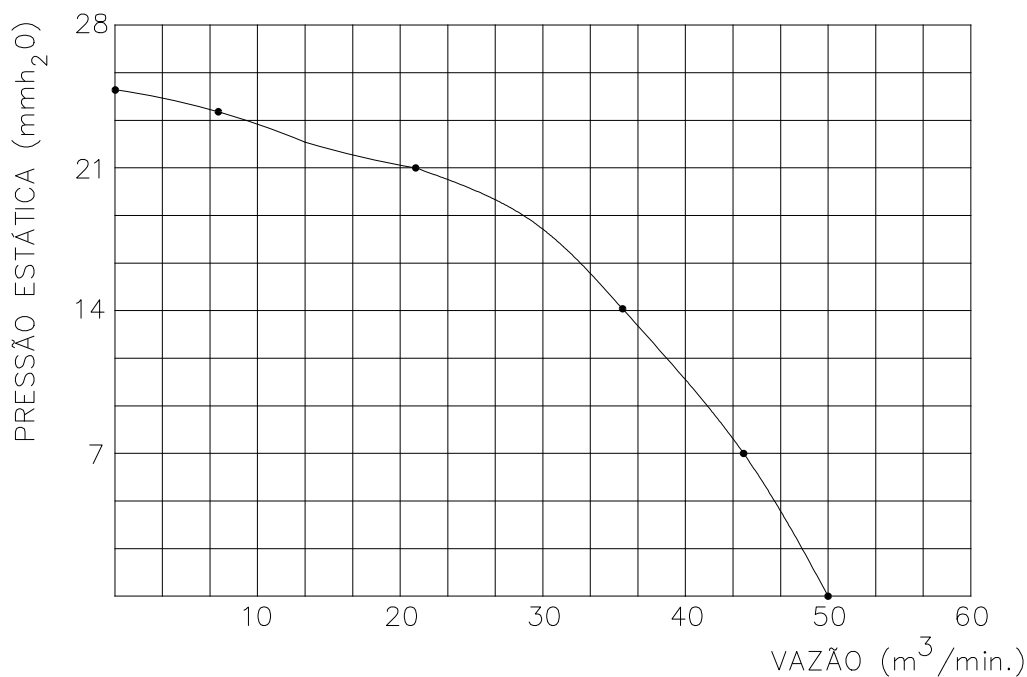

Todos os valores registrados neste folheto estão sujeitos a alterações sob critério do fabricante sem prévio aviso.

CÓPIA NÃO CONTROLADA

Qualitas Indústria Eletromecânica Ltda.
Av. Anésio Bazani, 240 Jardim Progresso Itapira-SP CEP-13973-532
Fone 19 3913-9300 - Fax 19 3913-9309 www.qualitas.ind.br



2404-7