

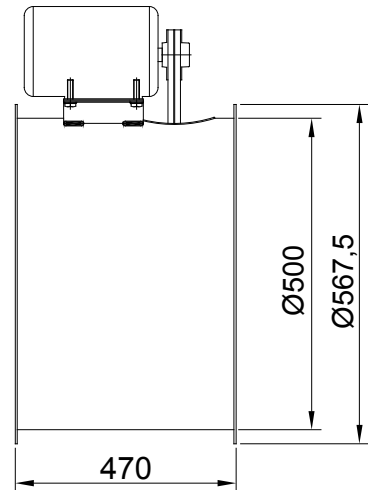

Exaustor EQ500TRM4

OBS. FOTO E DESENHOS ILUSTRATIVOS

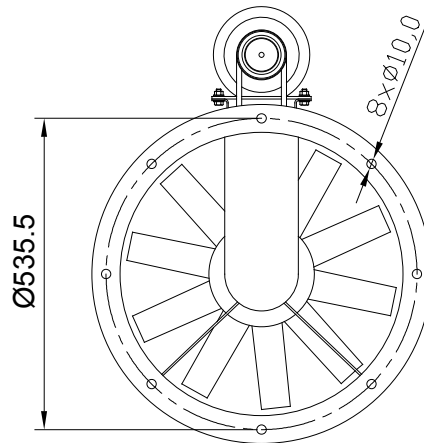

CURVA CARACTERÍSTICA
(20°C/760 mm Hg)

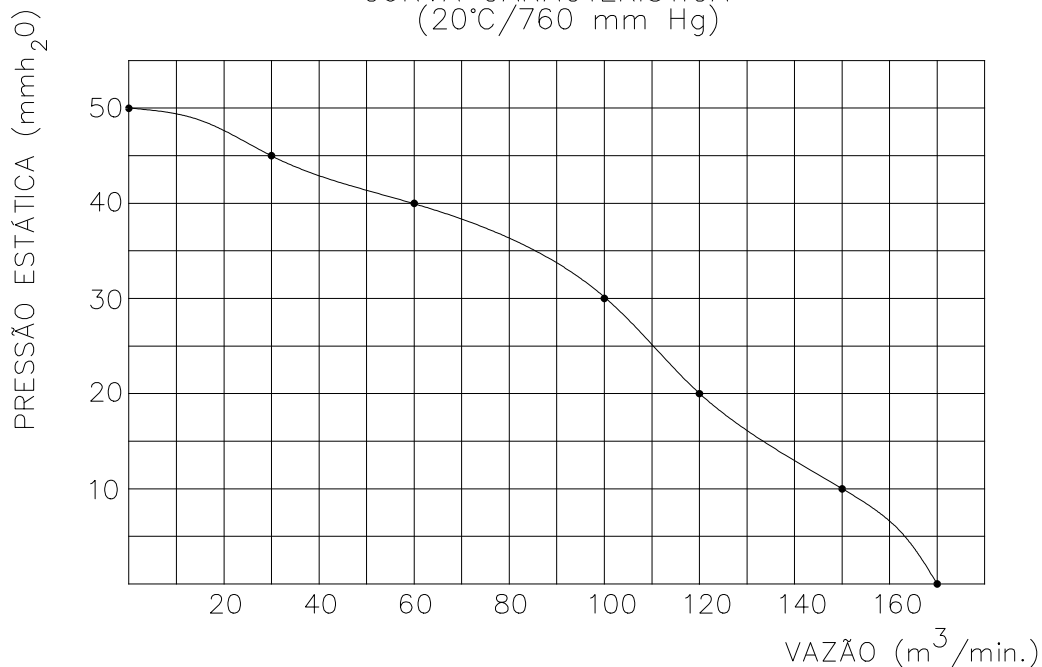

ESQUEMA DE LIGAÇÃO
VIDE PLAQUETA DO MOTOR

Todos os valores registrados neste folheto estão sujeitos a alterações sob critério do fabricante sem prévio aviso.

CÓPIA NÃO CONTROLADA

